



ACQUISITION INNOVATION  
RESEARCH CENTER

# Improving the Process for Developing Capability Requirements for Department of Defense (DoD) Acquisition Programs

EXECUTIVE SUMMARY AND REPORT  
SEPTEMBER 2023

**PRINCIPAL INVESTIGATOR:**

Michael McGrath, D.Sc, *Stevens Institute of Technology*

**RESEARCH SCIENTIST:**

Donald Schlomer, DBA, *Stevens Institute of Technology*

**PROFESSOR:**

Mo Mansouri, PhD, *Stevens Institute of Technology*

**SPONSORS:**

OFFICE OF THE UNDER SECRETARY OF DEFENSE FOR ACQUISITION AND  
SUSTAINMENT (OUSDA&S))  
UNITED STATES SPECIAL OPERATIONS COMMAND (USSOCOM)



DISTRIBUTION STATEMENT A.  
Approved for public release:  
distribution unlimited.

**RESEARCH TEAM**

NAME	ORG.	LABOR CATEGORY
Michael McGrath, D.Sc.	Stevens Institute of Technology	Principal Investigator (PI)
Donald Schlomer, DBA	Stevens Institute of Technology	Research Scientist
Mo Mansouri, PhD	Stevens Institute of Technology	Professor

## TABLE OF CONTENTS

EXECUTIVE SUMMARY .....	4
BACKGROUND.....	5
INTRODUCTION TO JCIDS .....	5
CALLS FOR JCIDS REFORM.....	7
PRIOR AIRC STUDY .....	8
STUDY APPROACH.....	8
ANALYSIS OF SOCOM SORRD AND CDD DATA .....	9
ANALYSIS OF SERVICES STREAMLINED PROCESSES .....	12
COMPLIANCE WITH JROC TITLE 10 AUTHORITY .....	13
INTERFACE WITH THE SYSTEMS ENGINEERING PROCESS.....	14
CONCLUSIONS, FINDINGS AND RECOMMENDATIONS .....	16
APPENDIX A. SENATE VERSION OF FY 24 NATIONAL DEFENSE AUTHORIZATION ACT .....	18
APPENDIX B. COLLABORATIVE GOVERNANCE: ORCHESTRATING REQUIREMENTS IN MULTI-SYSTEM ENVIRONMENTS.....	19
REFERENCES.....	21

## LIST OF FIGURES

FIGURE 1. JCIDS REVIEW AND APPROVAL ORGANIZATIONS.....	5
FIGURE 2. JCIDS DELIBERATE PATH .....	6
FIGURE 3. ADAPTIVE ACQUISITION FRAMEWORK.....	6
FIGURE 4. AIRC ASSESSMENT OF JCIDS TIMELINES.....	8
FIGURE 5. SORRD VALIDATION PROCESS.....	10
FIGURE 6. SORRD COMPARISON TO CDD .....	10
FIGURE 7. USSOCOM SORRD VALIDATION TIMES – 85 DAYS AVERAGE .....	11
FIGURE 8. SORRD PROCESS TIME COMPARED TO SOCOM CDD .....	11
FIGURE 9. JROC MISSION AND RESPONSIBILITIES .....	14
FIGURE 10. JCIDS INTERFACE WITH SYSTEMS ENGINEERING.....	15
FIGURE 11. EVOLVING AGILE PRACTICES IN SYSTEMS ENGINEERING.....	16

## LIST OF TABLES

TABLE 1. SERVICES’ STREAMLINED DOCUMENTS COMPARED TO CDD AND ICD.....	12
---	----

## EXECUTIVE SUMMARY

The Joint Capabilities Integration and Development System (JCIDS) is the Department of Defense's (DoD) formal requirements approval process. It is important to develop and validate joint warfighting capability needs as the basis for acquisition programs. However, for capabilities that need to keep pace with evolving technologies, process delays in requirements validation can cause commensurate delays in delivery of capabilities to the warfighter. The JCIDS deliberate path (as opposed to the JCIDS urgent path) is designed to strike a balance in speed and thoroughness but is often slow in practice.

In the FY 21 National Defense Authorization Act (NDAA), Congress expressed concern that JCIDS is too slow to keep pace with threats and technology, directing the DoD to develop recommendations for streamlining JCIDS. In support of the DoD's response, in 2022, the Acquisition Innovation Research Center (AIRC) modeled the JCIDS process and used the model to assess the effects of proposed process improvements [AIRC (2022)]. The 2022 AIRC study found that for a sample of 20 Navy programs, JCIDS staffing of a Capability Development Document (CDD) took an average of 336 days. The 2022 study also found that the Special Operations Command (SOCOM) had developed a streamlined requirements process that could reduce requirements review and approval times by more than 50%. The research team recommended that a SOCOM-like process be quantitatively assessed for speed, piloted in the Military Services, and, if successful, adopted for all but the largest acquisition programs as an alternative to JCIDS.

This report summarizes the follow-on analysis of the SOCOM process, verifying that it is indeed significantly faster than the JCIDS process. **The 15 Special Operations Rapid Requirements Documents (SORRDs) examined took an average of 85 days to validate compared to the 157 days on average for SOCOM to approve a full CDD (N=5).** Thus, the SORRD process is faster (about half as long) than its counterpart CDD process at SOCOM—and **much faster (about a fourth as long) than the average of 336 days for 20 Navy CDDs examined in the prior study.**

In discussing the SOCOM process with the Military Services in the current study, the research team learned that each Service has developed and implemented its own counterpart streamlined process for validating requirements for Middle-Tier Acquisition (MTA) programs, which are exempt from the JCIDS process by law. These Service and SOCOM streamlined processes have demonstrated much shorter times compared to JCIDS while meeting the basic needs of requirements document users in the acquisition and testing communities. Our assessment found sufficient evidence to recommend that the Joint Staff investigate delegating requirements validation to the Service streamlined processes for all programs other than Major Defense Acquisition Programs (MDAPs). Our team believes this recommendation is consistent with the statutory role of the Joint Requirements Oversight Council (JROC). To state the recommendation in implementable terms:

**Recommendation 1. For all requirements whose anticipated solution is a non-MDAP acquisition program, regardless of Adaptive Acquisition Framework (AAF) pathway, the Joint Staff should consider accepting a streamlined Sponsor document received by the Joint Staff Gatekeeper as an acceptable alternative to a JCIDS document. The default Joint Staff Determination (JSD) category should be "Joint Information," with delegation of requirements validation to the Sponsor. In cases where a Joint Performance Requirement exists, the Joint Staff should participate as reviewers in the Sponsor's review and approval process. By exception, a documented JROC or Joint Capabilities Board (JCB) expression of interest may change the JSD category and require JROC or JCB approval. Such exceptions should be rare for non-MDAP programs.**

The research team noted in this review that the Senate version of the FY 24 NDAA would direct the DoD to modernize the requirements process in ways that include streamlining for non-MDAP programs and would go well beyond that to require major restructuring of how requirements are developed and managed. If this becomes law, the DoD will have to make significant changes in the way the requirements process interfaces with the acquisition process. Today, that interface occurs through the systems engineering process. JCIDS is designed to interface with a linear, sequential systems engineering process with a handoff via the CDD. Systems engineering practice, however, is evolving to a more iterative, collaborative approach enabled by digital engineering tools and model-based methods for exploring trade space and optimizing designs. Mission engineering and capability portfolio management blur the lines between warfighter definition of capability needs and iterative engineering definition of solutions. Therefore, the research team recommends that the DoD plan for a joint effort by the requirements community and systems engineering community in modernizing the DoD requirements process in response to the FY 24 NDAA.

## BACKGROUND

In 2022, the Acquisition Innovation Research Center (AIRC) was asked to support the Office of the Secretary of Defense (OSD) and the Joint Staff organization in responding to Congressional direction to reduce latency in the Department of Defense (DoD) requirements process. The report on the Joint Capabilities and Integration System (JCIDS) provided recommendations to speed the current process and additional recommendations regarding structural changes that could further improve the process.

This report summarizes the results of a follow-on effort focused primarily on implementation of prior recommendations to speed the current process.

## INTRODUCTION TO JCIDS

The DoD faces a continual challenge to deliver capabilities to the warfighter that keep pace with rapidly advancing technologies available to our potential adversaries. The DoD's Adaptive Acquisition Framework (AAF) provides multiple pathways for more timely delivery of solutions to meet validated warfighting requirements. While the Major Capability Acquisition (MCA) pathway is well suited for platforms and systems where technology evolves slowly, other pathways are geared to faster insertion of technologies that provide a warfighting edge. However, a pacing front-end item for any acquisition program is the validation of the requirement being addressed. Validation is important to ensure the right capability is delivered. Bad requirements can cause acquisition failure. At the same time, any unnecessary delay in requirements validation directly delays capability delivery. The JCIDS process governs this validation process and is intended, ideally, to strike a balance between thoroughness and speed.

The JCIDS process is complex. As shown in Figure 1, there are multiple levels of Joint Staff functional working groups, integration groups, and review boards structured to support the top-level Joint Requirements Oversight Council (JROC), which is chaired by the Vice Chair of the Joint Chiefs of Staff. The responsibilities of these organizations and the policy for JCIDS are defined in a 118-page instruction [DoD (2021)]. The DoD components have similar organizations and policy documents. The staffing process for JCIDS documents is tailored to each individual capability need, but typically involves many of these Joint Staff review groups and their Service or Component counterparts.

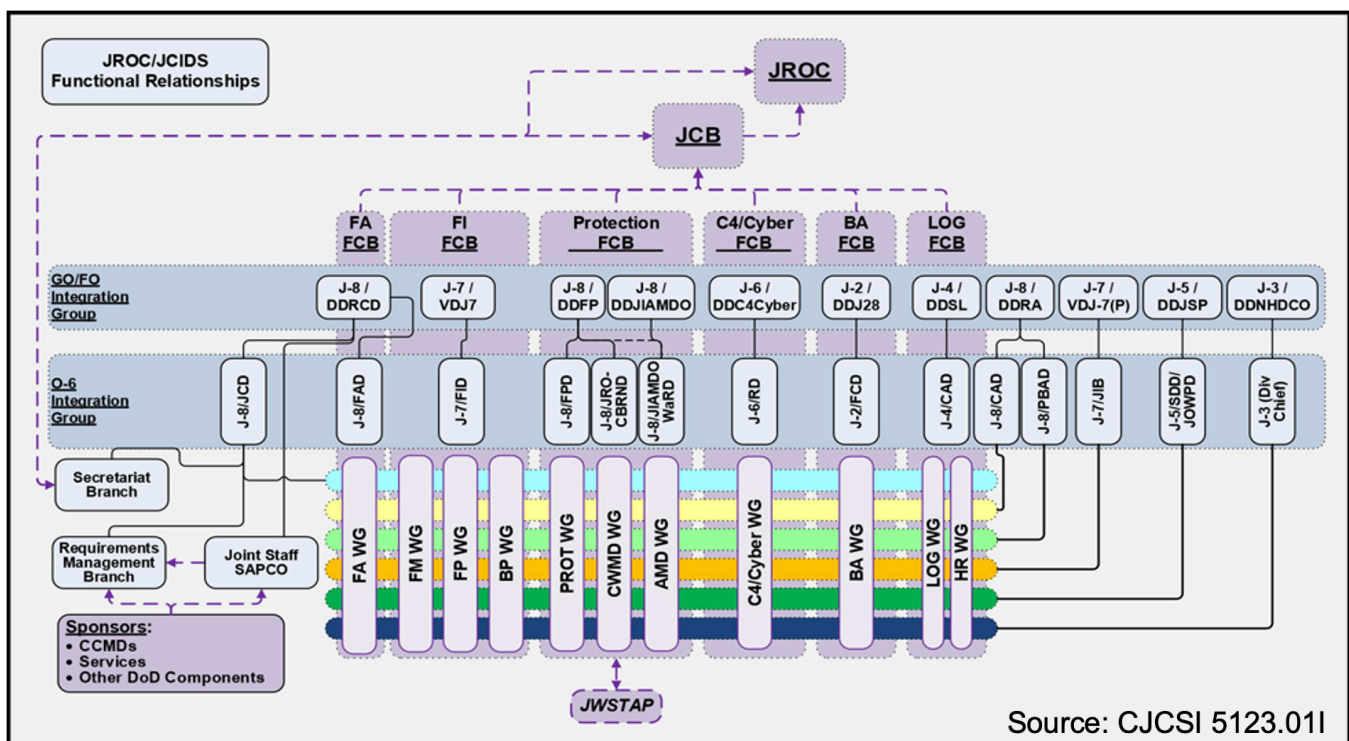
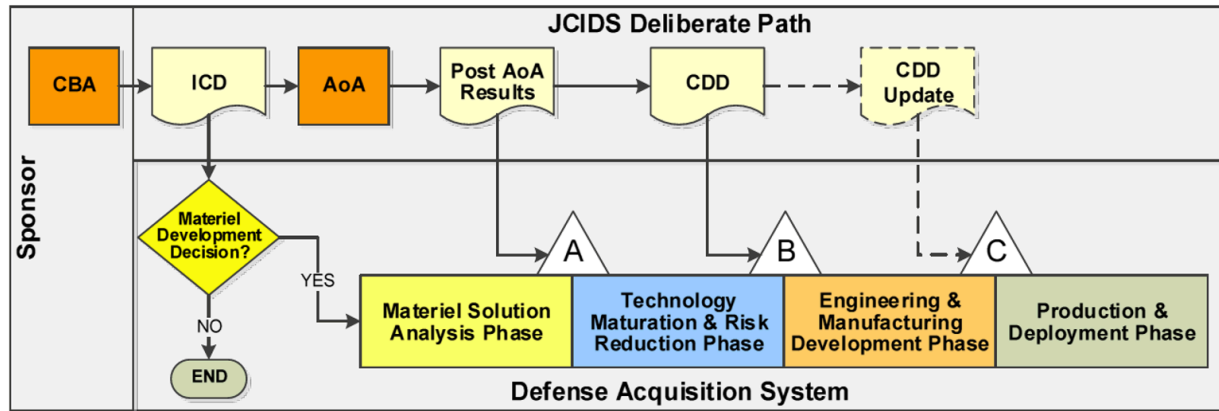

Figure 1. JCIDS Review and Approval Organizations

The JCIDS process steps and tailoring guidance are provided in a 399-page JCIDS Manual [DoD (2021a)]. JCIDS provides a streamlined path for Joint Urgent Operational Needs (JUONS) and Joint Emerging Operational Needs (JEONS), and a deliberate path for addressing future needs that require developing a material solution. Tailoring can be extensive since the same deliberate path applies to a need for a new fighter jet or a new jungle boot. As shown in Figure 2, the deliberate path is designed to interact with the Major Capability Acquisition Pathway defined in DoDI 5000.85 [DoD (2019)].



Source: JCIDS Manual (2021)

Figure 2. JCIDS Deliberate Path

DoD acquisition policy provides additional pathways (Figure 3) as elements of the AAF [DoD (2019)]. Other than urgent capability acquisition, these additional pathways are not yet explicitly addressed in the JCIDS Manual.

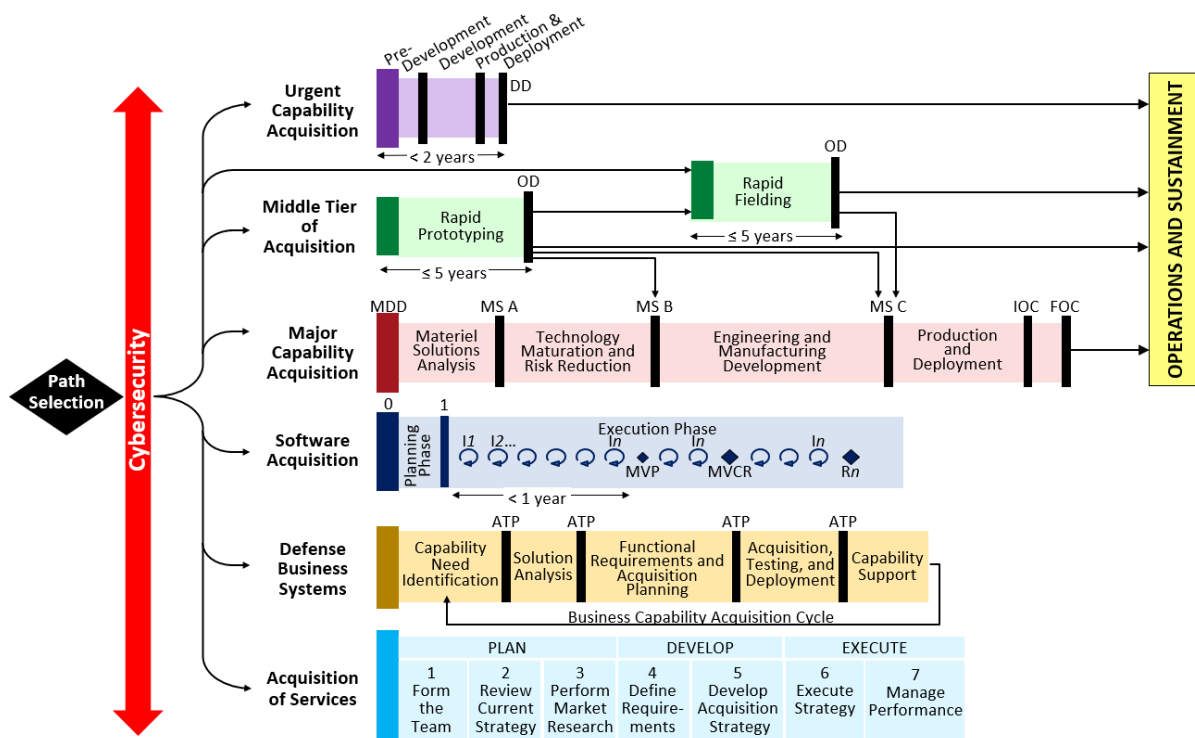

Figure 3. Adaptive Acquisition Framework

Source: DoDI 5000.80

A key to the success of the AAF has been the ability to tailor the acquisition process to each situation, with an emphasis on agility and speed. Also, the delegation of acquisition milestone decision authority to the Service Acquisition Executives and lower officials of lower-risk programs further streamlines these tailored acquisition processes. Major Defense Acquisition Programs (MDAPs) are programs that require more than \$525 million in Research, Development, Test and Evaluation (RDT&E) or more than \$3.065 billion in procurement (constant FY 20 dollars). By contrast, JCIDS is centrally managed by the Joint Staff, with acceptance of Services' validation processes only in cases where a single Service requirement is being addressed – a rarity in today's joint warfighting environment. This raises the question of whether alternative governance models could meet the statutory requirements of oversight by the JROC while delegating non-MDAP requirements validation authority to the Services.

For the JCIDS deliberate path in Figure 2, the first requirements document is an Initial Capabilities Document (ICD). The ICD is used to validate whether a material solution is needed, and, if so, to inform the Analysis of Alternatives (AoA) performed by the acquisition community. Often, however, the need for a material solution is known in advance of an AAF pathway and a prototype exists, in which case the ICD and AoA steps may be waived, and the sponsor proceeds directly to development of a Capability Development Document (CDD). The JCIDS Gatekeeper determines whether the CDD is categorized as (1) JROC Interest, (2) Joint Capabilities Board (JCB) Interest, or (3) Joint Information, based primarily on the sponsor's recommendation and whether the document contains joint performance requirements. If the determination is Joint Information, the validation process is delegated to the sponsor.

The JCIDS Manual sets goals of 67 days and 103 days, respectively, for the review and approval of an ICD or CDD. JCIDS has been widely criticized for not meeting these goals in practice [GAO (2021), Modigliani et al (2020)].

## CALLS FOR JCIDS REFORM

Speed matters. As Army AL&T Magazine [US Army (2023)] put it, "Key to today's modernization efforts is speed. JCIDS makes that very difficult to accomplish. The one-size-fits-all JCIDS process is onerous. Speed, however, is also associated with risk. Speeding capability-requirements generation in DoD may increase programmatic risk, but that's not the only dimension for risk and maybe not even the most important one. The risk inherent in going slow when peer threats blaze along could very well outweigh programmatic risk."

A 2020 MITRE report, "Modernizing DoD Requirements: Enabling Speed, Agility and Innovation," [Modigliani et al (2020)] recommended developing an adaptive requirements framework to correspond to the AAF. MITRE recommended a substantially new approach to requirements that would recognize warfighter enduring requirements and manage them in capability portfolios. MITRE also recommended revisiting boards, documents, and staffing, and rewriting the JCIDS manual from a clean sheet.

The MITRE report was cited in the House conference committee report accompanying the FY 2021 National Defense Authorization Act (NDAA). Section 809 of the FY 21 NDAA required DoD to assess the requirements process and develop recommendations to improve its agility and timeliness. In October of 2021, Government Accountability Office (GAO) Report GAO-22-104432 [ref], "Weapon System Requirements: Joint Staff Lacks Reliable Data on the Effectiveness of its Revised Joint Approval Process," examined the timeliness of 12 CDDs that followed the JCIDS process. The GAO report found that the data on timelines was unreliable and inconsistent, but that none of the capability documents completed the process within the JCIDS target of 103 days.

The most far-reaching call for requirements reform to date is the Senate version of the FY 24 NDAA. It requires DoD to modernize its requirements process. The full text of the pertinent section (Section 802) is at Appendix A. Key elements of the required reforms include:

1. Streamlining requirements documents, reviews, and approval processes, especially for non-MDAP programs.
2. Revisiting requirements management practices from a first principles perspective based on mission outcomes and assessed threats, enabling a more iterative and collaborative approach with the services to shape requirements and technology driven opportunities.
3. Developing a capability needs and requirements framework and pathways that are aligned to the Department's Adaptive Acquisition Framework pathways, and better aligned and integrated with the Department's science and technology processes.
4. Enabling the military departments to develop an enduring set of requirements according to a set of capability portfolios to provide a structure across acquisition programs and research, which shall be articulated in a concise model and document with a set of mission impact measures that capability deliveries will seek to continuously improve.
5. Establishing a process to rapidly validate the military utility of commercial solutions to meet capability needs or opportunities in lieu of the traditional program-centric requirements definition.
6. Retiring and replacing the Department of Defense Architecture Framework with a new structure focused on enabling interoperability through application program interfaces, enterprise architectures and platforms, and government and commercial standards.
7. Ensuring that requirements processes for software, artificial intelligence, data, and related capability areas enable a rapid, dynamic, and iterative approach than traditional hardware systems.



The Senate language would mandate that implementation of the streamlined requirements process include collaboration with industry and the science and technology community to ensure it effectively harnesses the innovation ecosystem. It would also mandate development of a formal career path and training for requirements management professionals and chief architects. As of the date of this report, implementation of these Senate mandates awaits the House/Senate conference and final passage of the FY 24 NDAA, but even if it does not become law the Senate language demonstrates strong Congressional concerns with the length of time in approving requirements.

## PRIOR AIRC STUDY

In 2022, AIRC conducted a study of JCIDS in support of the DoD’s response to the FY 21 NDAA. The AIRC study reviewed timeline data on 20 Navy requirements documents and found that the average time to approval for an ICD was 516 days and the average time to approval of a CDD was 336 days. As shown in Figure 4, these timespans do not include the time to develop the capability-based assessment nor the AoA. Clearly the JCIDS goals of 67 days and 103 days were not met for the programs we reviewed.

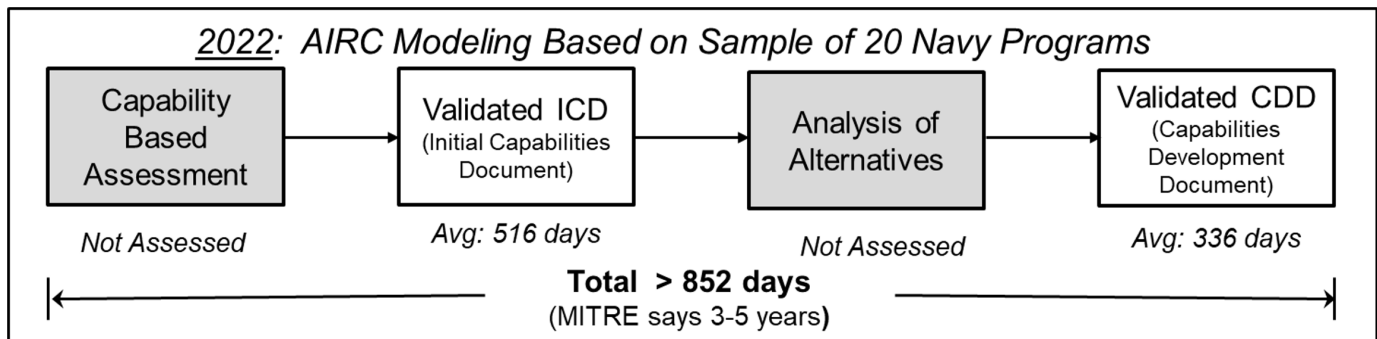

Figure 4. AIRC Assessment of JCIDS Timelines

The 2022 AIRC study examined ways to speed the current process and considered the need for structural changes in the process. We found that the Special Operations Command (SOCOM) had developed a streamlined process for the Middle Tier Acquisition (MTA) pathway of the AAF, and a streamlined document called the Special Operations Rapid Requirements Document (SORRD). Our simulation model showed that broad adoption of a SORRD-like process could achieve significant time savings in the Services. We recommended that such streamlined processes be piloted in the Services and, if successful, adopted as the standard approach for all non-MDAP programs. Most defense acquisition programs are smaller than MDAPs and would benefit from this recommendation.

Additional recommendations included: future JCIDS reform efforts clarify end-to-end governance of the requirements process and consider the interfaces among the requirements, acquisition, and resourcing processes; future efforts take advantage of digital engineering, mission/portfolio engineering, modular open system architectures, rapid prototyping, agile software/hardware development, cross-functional teams and other advances in the systems engineering (SE) community; and developing requirements career professionals, similar to the civilian acquisition professionals and financial management professionals the military relies on.

This current study focused primarily on our recommendations to speed the current process.

## STUDY APPROACH

This report summarizes our follow-on analysis of recommended improvements to the DoD requirements process. Our objectives were to: (1) verify that the SOCOM streamlined process is significantly faster than its counterpart JCIDS process, (2) evaluate the potential for similar streamlined processes in the Services, and (3) investigate alternative governance models and structural changes that could improve the JCIDS process.

For comparison to the Navy data in Figure 4, we collected data on 13 SOCOM programs that used the streamlined SORRD process and compared the staffing time to 5 SOCOM programs that used the counterpart JCIDS CDD process. For this small sample, **the average time to approval of a SORRD was 85 days versus 157 for a SOCOM CDD**, so the time savings is evident. The SORRD coordination process allows for Joint Staff inputs in parallel with SOCOM inputs. We held discussions with acquisition and test and evaluation (T&E) users of the SORRD document and learned that it not only met their needs, but it was also considered *preferable* to the details in a full CDD document because it *allowed more latitude for judgment and tradeoffs in engineering and testing processes*.



We met with requirements organizations in the Army, Navy, Air Force, and Marine Corps to discuss these results. For the MTA pathway, the Services have been explicitly exempted by law from the JCIDS process [10 U.S. Code, Ch. 221, Statutory Notes and Related Subsidiaries]. According to DoDI 5000.80 [DoD (2019)]:

*"MTA programs will not be subject to the guidance in Chairman of the Joint Chiefs of Staff Instruction 5123.01H and DoD Directive 5000.01. Each DoD Component will develop a streamlined process that results in a succinct requirement document no later than 6 months from the time the operational needs process is initiated. Approval authorities for each capability requirement will be delegated to a level that promotes rapid action."*

We note that DoDI 5000.87, "Operation of the Software Acquisition Pathway," [ref] provides a similar exemption from JCIDS for the Software pathway.

All Services have developed their own streamlined processes similar to the SORRD process for MTAs, and they now have several years of experience with these new processes and documents. The prior AIRC recommendation to pilot SORRD-like processes in the Services has, in effect, been accomplished. In discussions with the Service and SOCOM requirements organizations, we found unanimous support for recognizing these streamlined processes as acceptable alternatives to JCIDS — not only for the MTA pathway but also for non-MDAP programs in any AAF pathway.

We reviewed the Senate version of the FY 24 NDAA and noted that it would direct DoD to modernize the JCIDS process. We met with senior executives in the Office of the Assistant Secretary of Defense for Acquisition (ASD(A)) to discuss how our emerging study results might be the basis for OSD and Joint Staff collaboration with the Services in developing a modernized requirements process. Considering the broad scope of the NDAA modernization expectations, we conducted a literature review of systems engineering research that might apply to a modernized requirements process. As part of a separate AIRC task to support the Planning, Programming, Budgeting, and Execution (PPBE) Reform Commission, we provided inputs to a panel of experts who are developing recommendations to improve integration of the DoD Requirements, Resources and Acquisition processes, often referred to as "Big A" acquisition.

Our findings and recommendations, based on this research approach, are discussed in the sections that follow.

## ANALYSIS OF SOCOM SORRD AND CDD DATA

Our first task in this follow-on effort was to validate that the SORRD document and approval process does save time compared to the JCIDS CDD process. We visited the SOCOM Acquisition Executive (AE) and representatives of the USSOCOM J8-R requirements organization. The purpose was to obtain data on SORRD validation timelines and get approval to share the SORRD document format and staffing process with the Services.

The SORRD validation process (Figure 5) was established to validate the requirements document to be used to for SOCOM's MTA pathway. According to DoDI 5000.80, Operation of the Middle Tier of Acquisition [DoD (2019)], the MTA pathway may be used for rapid prototyping or rapid fielding acquisition strategies. SOCOM uses this streamlined process with aggressive timelines for rapid fielding MTAs, and with more deliberate timelines for rapid prototyping MTAs.



## People-Win-Transform SORRD Process

UNCLASSIFIED

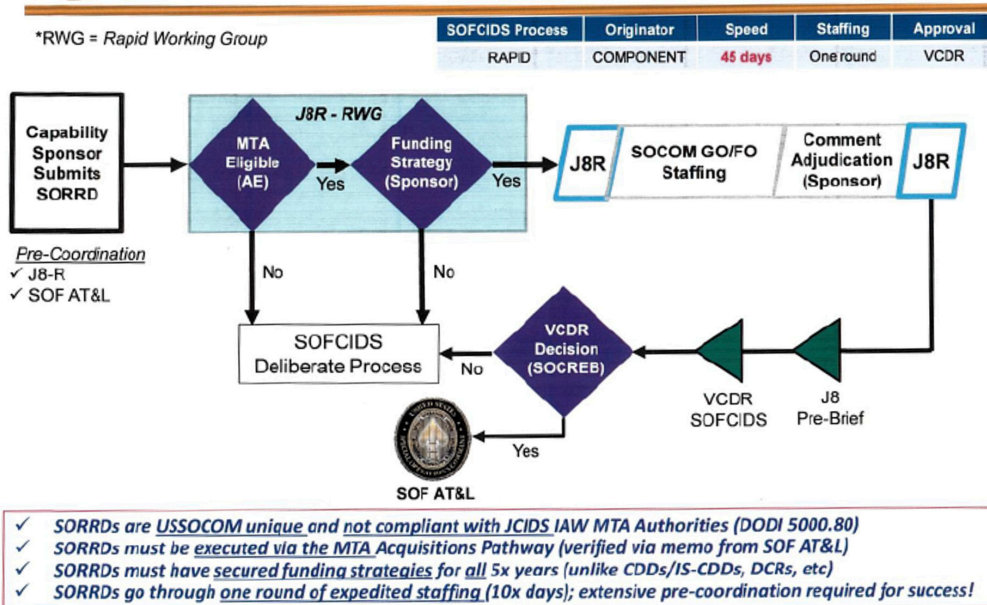

UNCLASSIFIED

Source: SOCOM

Figure 5. SORRD Validation Process

Our next step was to compare the scope and size of a SORRD to a JCIDS CDD. The SORRD is one third the size of a CDD, 12 pages vs 45 pages, because the SORRD has fewer chapters addressing only essential aspects of the MTA requirement (see Figure 6).



## People-Win-Transform CDDs vs. SORRDs

UNCLASSIFIED

Comparison			Document Sections		
Key Differences	CDD	SORRD	CDD	SORRD	
JCIDS Compliant	YES	YES	Operation Context	YES	YES
Recognized as Validated SO-p Requirement (JS J8)	YES	YES	Threat Summary	YES	NO
Document Sections	13	5	Capability Discussion	YES	YES
Page Count	<45	*None (<10)	Program Summary (IOC/FOC/SOPA)	YES	YES
Staffing Timeline	120 days	45 days	Performance Attributes) (KPPs, KSAs, APAs)	YES	YES
Joint Staff Designator	YES	NO	Other System Attributes	YES	NO
Mandatory KPPs/KSAs	YES	NO**	Joint Interoperability	YES	YES
DoDAF Architectures	YES	NO	Spectrum & Electromagnetic Environmental Effects Control Requirements (EM/E3)	YES	NO
Certifications & Endorsements	YES	NO	Intelligence Supportability	YES	NO
Appendices	YES	NO	Weapon Safety Assurance	YES	NO
Requirement Validation Period	Indefinite*	5 Years	Technology Readiness	YES	NO
Resourcing Commitment	Indefinite***	5 Years	DOTmLFP-P Considerations	YES	NO
Acquisition Options	*All	MTA Only / MSB	Program Affordability	YES	YES
Can utilize funds in PB/BES	*Not typically	YES			

\* Until Requirement is Rescinded  
\*\* Some (not all) are included within SORRDs  
\*\*\* Until Capability is Divested

UNCLASSIFIED

Source: SOCOM

Figure 6. SORRD Comparison to CDD

SOCOM provided validation timeline data on a sample of 13 SORRDs and 5 SOCOM CDDs. As discussed previously, the JCIDS process sets a goal of 103 days for validation of a CDD, a goal that is almost never met in practice and was grossly exceeded in the Navy CDDs reviewed in our prior study. Figure 7 shows the timelines for the 13 SORRDs, which averaged 85 days to approval after submission of the SORRD. The time to generate the SORRD and approve it for submission is about 60 days, and is not included in this validation time. However, since the generation and approval for submission time for a SOCOM CDD is typically 90-120 days, the SORRD saves even more time compared to a CDD.

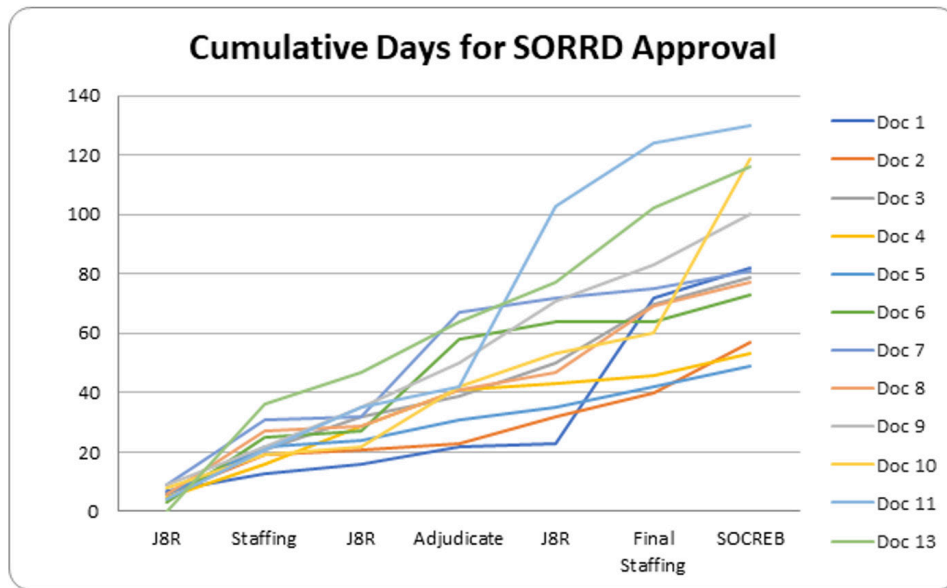

Figure 7. USSOCOM SORRD Validation Times – 85 Days Average

We examined the distribution of approval times for the sample of SORRDs and SOCOM CDDs and found that the SORRD process is clearly faster (Figure 8). For this small sample, the SORRD average of 85 days (N=13) was a little more than half the average of 157 days (N=5) required for approval of a CDD at SOCOM.

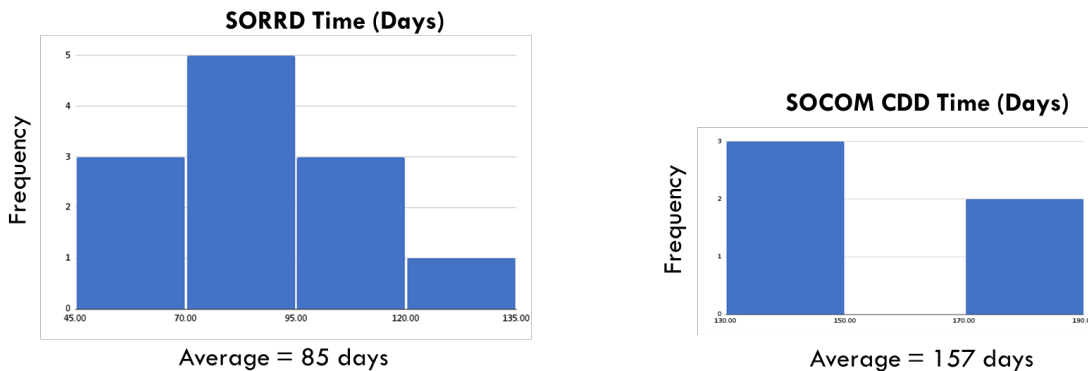

Figure 8. SORRD Process Time Compared to SOCOM CDD

This comparison verifies that the SORRD process is faster (almost by half) than its counterpart CDD process at SOCOM, and much faster (about a fourth) than the prior study’s average of 336 days for Navy CDDs.

Since the data showed that SORRD review and approval could be (and often was) completed in less than the 85-day average, we proposed a workshop with SOCOM to examine ways to make all SORRDs as fast as the best examples in our sample. The SOCOM organization, however, responded that the current timelines met their needs and that SORRDs needing expedited processing already get special treatment.

## ANALYSIS OF SERVICES STREAMLINED PROCESSES

Our next step was to meet with representatives of requirements organizations in the Army, Navy, Air Force, and Marines, in addition to meeting with the Military Deputy to the Navy Acquisition Executive. In each meeting we presented the results of our prior study and its recommendation that the Services could use a SORRD-like document and process to streamline their requirements validation processes. We immediately learned that each Service had created its own streamlined document and process and had been successfully using them on MTA programs. The following documents have been created by each service:

Army	Abbreviated CDD (A-CDD)
Navy	Top Level Requirement (TLR)
Air Force	MTA Capability Document (CD)
Marines	MTA Document

We compared the different streamlined documents to the JCIDS ICD and CDD document contents (Table 1). Since SOCOM SORRD documents are the basis for MTA programs that may be less complex than those of the Services, or may deal with technologies that are more mature, differences between the SORRD and Service documents are not surprising.

		Document Type						
		JCIDS CDD	SO COM SORRD	Army A-CDD	Navy TLR	Air Force MTA	USMC USON	JCIDS ICD
<b>Document Sections</b>	Operation Context	Yes	Yes	Yes	Yes	Yes	Yes	Yes
	Threat Summary	Yes	No	Yes	Yes	Yes	Yes	Yes
	Capability Discussion	Yes	Yes	Yes	Yes	Yes	Yes	Yes
	Program Summary	Yes	Yes	Yes	No	No	Yes	Yes
	Performance Attributes	Yes	Yes	Yes	Yes	No	Yes	No
	Other System Attributes	Yes	No	Yes	No	Yes	No	No
	Joint Interoperability	Yes	Yes	Yes	Yes	Yes	Yes	No
	Electromagnetic Control	Yes	No	Yes	No	No	No	No
	Intelligence Support	Yes	No	Yes	No	Yes	No	No
	Weapon Safety	Yes	No	Yes	No	No	No	No
	Tech Readiness	Yes	No	Yes	No	No	Yes	No
	DOTmLPP-P	Yes	No	Yes	Yes	Yes	No	No
Affordability	Yes	Yes	Yes	Yes	Yes	Yes	No	

*Table 1. Services' Streamlined Documents Compared to CDD and ICD*

All Services reported that their streamlined documents were reviewed and approved in less time than a JCIDS CDD. There were differences among the Services and SOCOM not only in the streamlined document contents, as shown in Table 1, but also in the approval process. For example, in the Army Futures Command process the Joint validation takes place after the Army validation, thus extending the process. The SOCOM process (Figure 5) includes Joint comments in parallel with the SOCOM staffing. We did not, in this study, attempt to identify a single best document format or validation process for use by all the Services. By providing this comparison data to the Services and SOCOM we have prompted discussions that may lead to best practices adoption.

The Service streamlined documents are validated outside the JCIDS process to support an acquisition that may follow the MTA pathway. The streamlined requirement documents are comparable to a CDD, but shorter and faster to prepare and validate. If the MTA pathway is the intent, then the solution is known to the extent needed to proceed with rapid prototyping or rapid fielding. We discussed with the Services whether

streamlined documents could take the place of JCIDS documents for all non-MDAP programs, not just MTAs. For smaller programs, called Acquisition Category (ACAT) II-IV programs, the early requirement (equivalent to an ICD) goes through a Service validation process, analysis of alternatives is conducted that is appropriate to the size of the acquisition decision being made, and a streamlined CDD-like document is prepared. Our assessment is that the streamlined requirement documents could meet the intent of JCIDS validation if the Service validation process provides opportunity for participation by Joint Staff and other Components in reviewing joint performance requirements.

The prior AIRC report recommended pilot programs to verify that streamlined documents and processes could be accepted for DoD requirements validation for all ACAT II-IV programs. In light of the Services and SOCOM experience in using such streamlined documents to support MTAs, our assessment is that the evidence exists to support this recommendation. We note that this recommendation could have a large impact since DoD currently has only about 100 active ACAT I programs, and over 800 smaller acquisition programs.

## COMPLIANCE WITH JROC TITLE 10 AUTHORITY

Any recommended change to the JCIDS process needs to be compatible with the statutory role of the JROC. The role and purpose of the JROC is defined by 10 U.S. Code § 181 - Joint Requirements Oversight Council. The relevant portion of the code states:

*The Joint Requirements Oversight Council shall assist the Chairman of the Joint Chiefs of Staff in—*

- 1) *assessing joint military capabilities, and identifying, approving, and prioritizing gaps in such capabilities, to meet applicable requirements in the national defense strategy under section 113(g) of this title;*
- 2) *increasing awareness of global trends, threats, and adversary capabilities to address gaps in joint military capabilities and validate joint requirements developed by the military departments;*
- 3) *reviewing and validating whether a capability proposed by an armed force, Defense Agency, or other entity of the Department of Defense fulfills a gap in joint military capabilities;*
- 4) *approving joint performance requirements that—*
  - (a) *ensure interoperability, where appropriate, between and among joint military capabilities; and*
  - (b) *are necessary, as designated by the Chairman of the Joint Chiefs of Staff, to fulfill capability gaps of more than one armed force, Defense Agency, or other entity of the Department.*

The last responsibility – approving joint performance requirements (JPRs) – is an important factor in the Joint Staff Determination of whether a requirements document should be handled as JROC interest, JCB Interest, or delegated to the Sponsor validation process as a Joint Information document. Most ACAT II and III programs are intended for use in joint operations and are likely to have JPRs. It is therefore important that any alternative to the JCIDS process provide for Joint Staff participation in the review process. Today, reviews of JPRs are part of the process managed by the Joint Staff, with Sponsor participation. Our proposed alternative is for Joint Staff organizations and other DoD components to participate in the Sponsor's streamlined review process to accomplish the same objectives for all ACAT II and III programs.

The statutory excerpt above defines only a subset of the JROC responsibilities shown in Figure 9, all of which need to be considered. In particular, accepting input from the Combatant Commands (CCMDs) is handled within JCIDS by the Joint Staff, assigning a CCMD-submitted requirement to a Service sponsor for action. This process can remain open to CCMD input under our proposed alternative. Once assigned to a Service sponsor, if the anticipated solution is a non-MDAP program, a streamlined requirements document would be submitted as the next step.



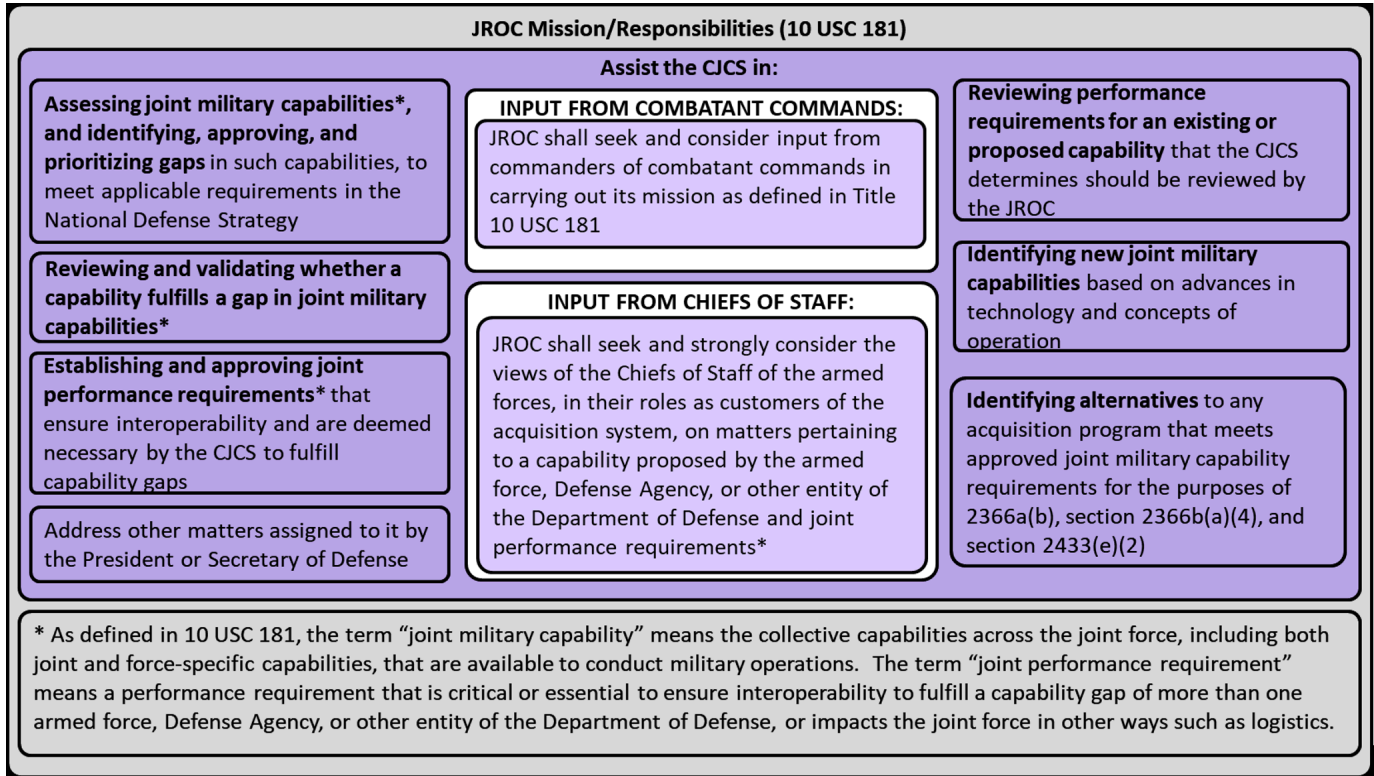

Source: CJSCI 5123.011

Figure 9. JROC Mission and Responsibilities

Our assessment is that JROC Title 10 responsibilities can be met under our recommended alternative of delegating requirements validation to the Sponsor’s streamlined process for non-MDAP programs, with Joint Staff participation in the Sponsor’s review process.

## INTERFACE WITH THE SYSTEMS ENGINEERING PROCESS

The Senate version of FY 24 NDAA Section 802 (Appendix A) calls for extensive reforms in the DoD requirements process, well beyond the streamlining we have proposed here. The DoD will be developing new requirements approaches whose primary interface with acquisition is executed through the systems engineering process. In the current JCIDS process, the interface with systems engineering is a linear sequential approach, with a handoff from the requirements community via the CDD as shown in Figure 10. Systems engineering practice, however, is evolving to a more collaborative and iterative approach not only for software, but also for hardware [AIRC (2023)]. Advances in digital engineering are revolutionizing the way system engineering explores trade space and optimizes designs.

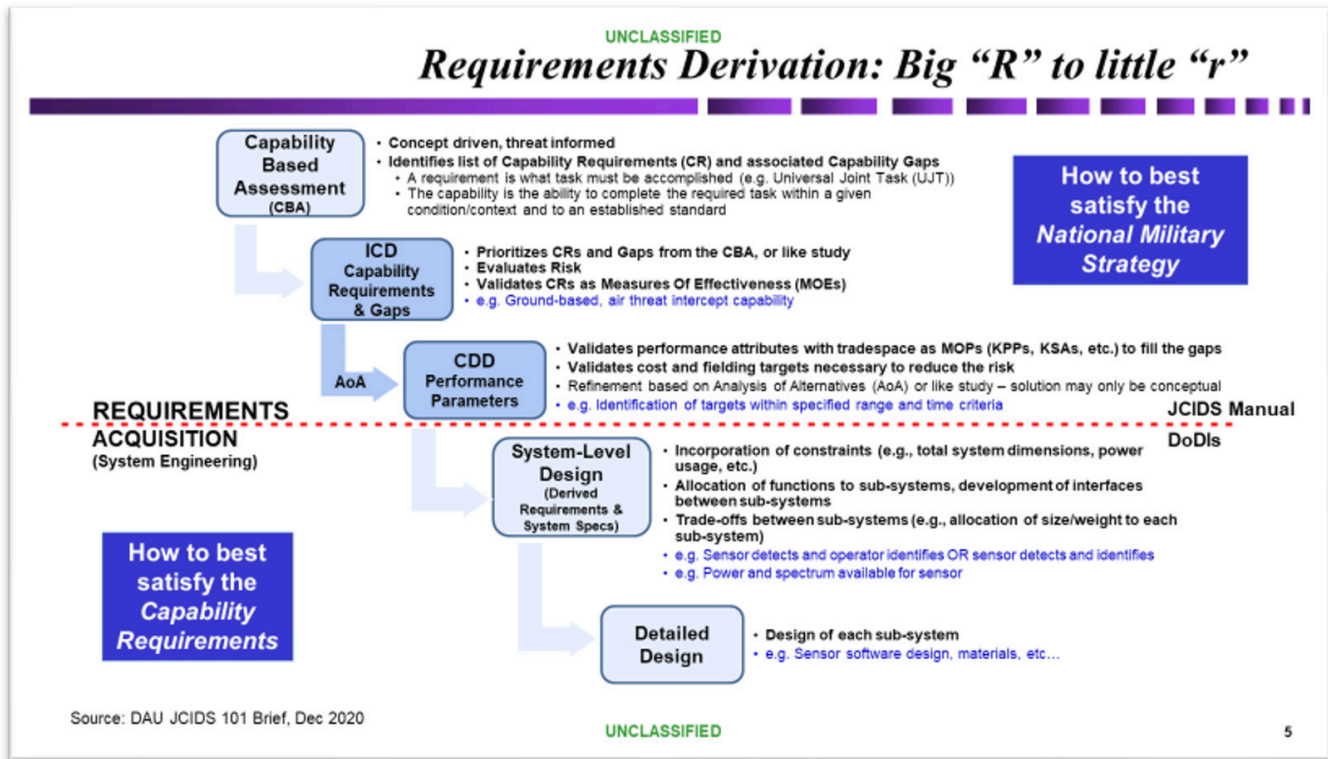

Figure 10. JCIDS Interface with Systems Engineering

Further, in DoD practice, systems engineering is evolving to include mission engineering and system of systems engineering – topics that are well aligned with the Appendix A Congressional direction on requirements process modernization. This direction aligns with cutting edge research in systems engineering and with emerging concepts for portfolio-based approaches in the context of mission engineering. Figure 11 summarizes evolving agile systems engineering practices to improve the flow from warfighter need to capability delivery. A key concept is to avoid a single batch mindset in addressing a need. Research and development in digital engineering is a strong enabler to streamlining and ensuring cross functional equities regarding requirements and their dynamic nature in response to the threat environment.

Since joint interoperability is an important objective of DoD requirements development, AIRC conducted a literature review on system of systems engineering and the concept of governance mechanisms to control interfaces. The results are summarized in Appendix B and are offered in support of future DoD development of mission engineering and portfolio-based approaches and the interface of the DoD requirements process with systems engineering disciplines.





Results from the SERC/AIRC and SEI Workshop: Agile for HW-Intensive Systems:

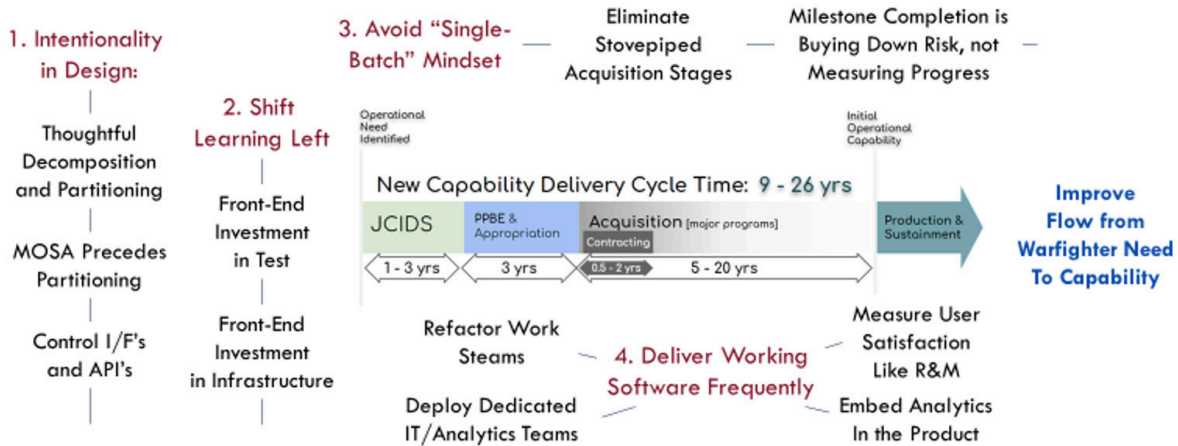

AIRC | SERC 9

Figure 11. Evolving Agile Practices in Systems Engineering

## CONCLUSIONS, FINDINGS AND RECOMMENDATIONS

This study focused on validating the feasibility of our prior recommendation on streamlining the DoD requirements process to be better aligned with fast moving technologies. We found that **SOCOM and the Services have implemented streamlined requirements documents and processes for MTA programs that are faster to develop, review, and approve than JCIDS documents, and meet the needs of requirements document users in acquisition and T&E. These streamlined processes show that delegation to the Services of non-MDAP programs is an effective means of speeding requirements validation, taking advantage of AAF pathways, and ultimately, speeding delivery of material solutions to warfighter capability needs.**

Based on this finding, we recommend **for all requirements whose anticipated solution is a non-MDAP acquisition program, the Joint Staff should consider accepting a streamlined Sponsor document received by the Joint Staff Gatekeeper as an acceptable alternative to a JCIDS document. The default Joint Staff Determination (JSD) category should be "Joint Information," with delegation of requirements validation to the Sponsor. In cases where a JPR exists, the Joint Staff should participate as reviewers in the Sponsor's review and approval process. By exception, a documented JROC or JCB expression of interest may change the JSD category and require JROC or JCB approval. Such exceptions should be rare for non-MDAP programs.**

This recommendation would respond directly to the Senate FY 24 NDAA requirement for "Streamlining requirements documents, reviews, and approval processes, especially for programs below the major defense acquisition program threshold described in section 4201 of title 10, United Stated Code." If that requirement is in the final bill, we see this recommendation as a first step that could easily be implanted within the existing Joint Staff Gatekeeper JSD process.

Modernizing the DoD requirements process as mandated by Congress goes well beyond this first step. Modernization can benefit from recent research in the systems engineering community regarding a more collaborative and iterative approach to systems engineering, governance concepts in systems of systems engineering, and mission engineering. We encourage joint efforts by the DoD requirements and systems engineering communities on requirements process modernization.

## ACRONYMS AND ABBREVIATIONS

AAF	Adaptive Acquisition Framework
ACAT	Acquisition Category
A-CDD	Abbreviated Capability Development Document
AIRC	Acquisition Innovation Research Center
AoA	Analysis of Alternatives
ASD(A)	Office of the Assistant Secretary of Defense for Acquisition
CCMD	Combatant Command
CDD	Capability Development Document
DoD	Department of Defense
GAO	Government Accountability Office
ICD	Initial Capabilities Document
JCB	Joint Capabilities Board
JCIDS	Joint Capabilities Integration and Development System
JEONS	Joint Emerging Operational Needs Statement
JPR	Joint Performance Requirement
JROC	Joint Requirements Oversight Council
JSD	Joint Staff Determination
JUONS	Joint Urgent Operational Needs Statement
MCA	Major Capability Acquisition
MDAP	Major Defense Acquisition Program
MOA	Memorandum of Agreement
MOU	Memorandum of Understanding
MTA	Middle Tier Acquisition
MTA CD	Middle Tier Acquisition Capability Document
NDAA	National Defense Authorization Act
OSD	Office of the Secretary of Defense
PPBE	Planning, Programming, Budgeting, and Execution
RDT&E	Research, Development, Test and Evaluation
SE	Systems Engineering
SEP	Systems Engineering Plan
SLA	Service Level Agreement
SOCOM	Special Operations Command
SORRD	Special Operations Rapid Requirements Document
SoS	System of Systems
T&E	Test and Evaluation
TLR	Top Level Requirement
USSOCOM	United States Special Operations Command

## APPENDIX A. SENATE VERSION OF FY 24 NATIONAL DEFENSE AUTHORIZATION ACT

(See Sec. 802 of H.R.2670 as amended by the Senate on 27 July 2023. [Text - H.R.2670 - 118th Congress \(2023-2024\): National Defense Authorization Act for Fiscal Year 2024](#) | [Congress.gov](#) | [Library of Congress](#).)

### SEC. 802. MODERNIZING THE DEPARTMENT OF DEFENSE REQUIREMENTS PROCESS.

- (a) MODERNIZING THE DEPARTMENT OF DEFENSE REQUIREMENTS PROCESS. Not later than October 1, 2025, the Secretary of Defense, acting through the Vice Chairman of the Joint Chiefs of Staff, in cooperation with the Secretaries of the military departments and the commanders of the combatant commands, and in coordination with the Under Secretary of Defense for Acquisition and Sustainment, shall develop and implement a streamlined Department of Defense requirements process, to include modernizing the Joint Capabilities Integration and Development System, in order to improve alignment between modern warfare concepts, technologies, and system development and reduce the time to delivery of needed capabilities to Department users.
- (b) REFORM ELEMENTS. The modernization activities conducted under subsection (a) shall include the following elements:
- (1) Streamlining requirements documents, reviews, and approval processes, especially for programs below the major defense acquisition program threshold described in section 4201 of title 10, United States Code.
  - (2) Revisiting requirements management practices from a first principles perspective based on mission outcomes and assessed threats, enabling a more iterative and collaborative approach with the services to shape requirements and technology driven opportunities.
  - (3) Developing a capability needs and requirements framework and pathways that are aligned to the Department's Adaptive Acquisition Framework pathways, and better aligned and integrated with the Department's science and technology processes.
  - (4) Enabling the military departments to develop an enduring set of requirements according to a set of capability portfolios to provide a structure across acquisition programs and research, which shall be articulated in a concise model and document with a set of mission impact measures that capability deliveries will seek to continuously improve.
  - (5) Establishing a process to rapidly validate the military utility of commercial solutions to meet capability needs or opportunities in lieu of the traditional program-centric requirements definition.
  - (6) Retiring and replacing the Department of Defense Architecture Framework with a new structure focused on enabling interoperability through application program interfaces, enterprise architectures and platforms, and government and commercial standards.
  - (7) Ensuring that requirements processes for software, artificial intelligence, data, and related capability areas enable a rapid, dynamic, and iterative approach than traditional hardware systems.
- (c) ELEMENTS. The implementation of streamlined requirements shall include the following elements:
- (1) Collaboration with industry, traditional and non-traditional defense companies, and the science and technology community to capture their inputs and feedback on shaping the Department's requirements processes to ensure it effectively harnesses the innovation ecosystem.
  - (2) Development of a formal career path, training, and structure for requirements management professionals and chief architects.
  - (3) Publication of new policies, guidance, and templates for the operational, requirements, and acquisition workforce in online digital formats instead of large policy documents.
- (d) INTERIM REPORT. Not later than October 1, 2024, the Secretary of Defense shall submit to the congressional defense committees an interim report on the modernization conducted by the Secretary under subsection (a), including:
- (1) a description of the modernization efforts;
  - (2) the Department of Defense's plans to implement, communicate, and continuously improve the modernization of the Department's requirements processes and structure; and
  - (3) any additional recommendations for legislation that the Secretary determines appropriate.
- (e) FINAL REPORT. Not later than October 1, 2025, the Secretary of Defense shall submit to the Secretary of Defense and the congressional defense committees a final report describing activities carried out pursuant to subsections (b) and (c).

## APPENDIX B. COLLABORATIVE GOVERNANCE: ORCHESTRATING REQUIREMENTS IN MULTI-SYSTEM ENVIRONMENTS

### Overview

An important JROC responsibility, whether delegated to a Service sponsor or performed by the JROC itself, is approving joint performance requirements that ensure interoperability between and among joint military capabilities. In the complex system of systems that provide joint military capabilities, defining system architecture, interfaces, human interactions and governance mechanisms are challenging technical considerations for requirements developers and systems engineers. Academic research on these topics has produced new concepts and methods that are available to DoD as resources to support modernization of the requirements process. In the Interface with the Systems Engineering Process section of this report we described the ongoing evolution of systems engineering from a sequential waterfall process to a more collaborative, iterative style of agile development for both software and hardware. In this Appendix, we offer a survey of academic research on collaborative governance concepts for multi-system environments. Our intent is both to provide a resource and an illustration of the type of ongoing systems engineering research that may be relevant to future DoD efforts in requirements modernization.

### Introduction

In cases where system components exhibit interdependence for functional fulfillment, the imperative for integration arises due to their inability to autonomously achieve their intended collective purpose. Quandaries emerge when constituent systems that operate independently and self-sufficiently attaining their objectives come together to form a coalition of systems. In that case, a systems must collaborate to achieve collective objectives and unlock capabilities that surpass their individual capacities, benefiting both the end customer and the individual systems. Thereby as (Sage et al. 1998) stated, each system engineer is responsible for the functioning of his or her own system, but one must design and control the integration needs and requirements, as well as develop the services that permit interaction. In this context, Sauser et. al (2009) have expounded upon the control paradox of autonomous systems, emphasizing the shift from 'management' to 'governance,' wherein 'control' is delineated as contingent upon rules of ownership, time, and bandwidth, while 'command' hinges upon principles of trust, influence, fidelity, and agility.

### Hurdles to Overcome

Sage and Cuppan (2001) emphasize the complexity of operational concepts required for interdependent systems, underscoring the multifaceted requirements inherent in defining, developing, and deploying such systems. That means that even when the constituent systems fulfill their individual local requirements, achieving the overall capabilities of the SoS could be challenging. This phenomenon, elucidated in one of the seven pain points identified by (INCOSE) termed Capabilities and Requirements, arises due to contrast between traditional SE and SoS. In defining requirements for SoS, constituent communities of interest may have some interests in common, but they often hold conflicting values and beliefs. According to Maier (1998), conflicts can arise due to the managerial and operational autonomy of the constituents. Jackson (2003) contends that decisions are made based on who possesses the most authority and the various modes of coercion used to secure compliance with orders. That may lead to "opportunistic behavior"; that means, according to Meadows (2009), the constituent systems do not foresee, or maybe choose to ignore, considering the values of the entire system. Furthermore, at best, even if the constituent systems seek to adhere to the SoS capabilities and values, systems rarely see the full range of possibilities and do not know what other systems are planning to do. That is supported by the Systems Engineering Book of Knowledge (SEBoK (P 714)) observation that failures often occur when the operator of one constituent system makes decisions based on inadequate knowledge of the overall SoS. This is not to say that the constituent systems authorities do not consider or seek to neglect the SoS values, we are simply being frank about the reality that we do our best to make rational decisions, but we can only consider what we already know. We are unaware of the intentions of others until they really act (Meadows 2009).

### The Need

This holistic perspective acknowledges that solutions to these problems extend beyond technical solutions alone. This necessitates a governing authority on the top level that aligns the capabilities of the constituent systems with the overall objectives of the coalition and its absence can result in a fragmented system with a cottage industry-like structure. Such arrangements offer considerable advantage to the organizations involved as they enhance the overall understanding and communication between the parties as stated by Henshaw et al. (2013). This, in turn, enhances the overall mutual development of the problem and solution space, providing clear insight into the range of pertinent perspectives of the requirements.

### The Tools

On that level, we agree with Henshaw et. al. (2013) as he stated that co-operation and collaboration between constituent systems must be negotiated, and then maintained by some form of service level agreements (SLAs) and contracts for the entire lifecycle. Henshaw et. al. (2013) postulate that governance can be regarded as a set of trust and contract relationships between systems including both informal and formal relationships. In the same context, the Guide for Integrating Systems Engineering into DoD Acquisition Contracts (DoD Guidebook) mentioned memorandums of agreement (MOAs) or understanding (MOUs) are useful to formalize the relationships between the coalition and the systems, specifies the responsibilities and other aspects of their SoS related working relationships. The DoD Guidebook highlighted that it is as important that the team creates a Systems Engineering Plan (SEP) that focuses on five key areas, namely Program Requirements, Technical Staffing and Organization Planning, Technical Baseline Management, Technical Review Planning, and Integration with Overall

Program Management. Different efforts create SE councils or other organizational entities as the vehicle for this type of cooperative activity. Similarly, different efforts have employed a variety of work breakdown structures to organize their efforts.

Several authors have employed various tools and techniques at that level, including Adaptive Multi-Agent Systems as utilized by Bouziat et al. (2018); System Portfolio by Li et al. (2018) and Ge et al. (2014); Modelling tools as demonstrated by Hu et al. (2014a), Hu et al. (2014b), Mordecai et al. (2013), and Mordecai et al. (2018); as well as Road mapping, as discussed in Muller et al. (2019). All of these studies offer valuable approaches for addressing high-level requirements effectively. Please refer to the studies for further information.

#### Appendix B References

1. INCOSE Systems Engineering Handbook, 4th Edition, John Wiley & Sons Inc., 2015
2. SEBoK (Systems Engineering Body of Knowledge) Editorial Board. 2022. The Guide to the Systems Engineering Body of Knowledge (SEBoK), v. 2.7, R.J. Cloutier (Editor in Chief). Hoboken, NJ: The Trustees of the Stevens Institute of Technology. Accessed [DATE].
3. Maier, M.W. (1998). Architecting Principles for Systems-of-Systems. *Systems Engineering*. 1(4), pp. 267–284.
4. Sage, A., and C. Cuppan. 2001. "On the Systems Engineering and Management of Systems of Systems and Federations of Systems." *Information-Knowledge-Systems Management Journal*. 2 (4): 325-345.
5. DoD. 2006. Guide for Integrating Systems Engineering into DoD Acquisition Contracts. Washington, DC, USA: Office of the Undersecretary of Defense for Acquisition, Transportation, and Logistics (AT&L), US Department of Defense (DoD)
6. Jackson, S. 2003. "Principles of Systems Engineering" from the lecture note used in the course called Systems Engineering Theory and Practice at University of Southern California.
7. Sage, Andrew P., and Charles L. Lynch. 1998. "Systems Integration and Architecting: An Overview of Principles, Practices, and Perspectives." *Systems Engineering* 1 (3): 176-227.
8. T. Bouziat, V. Camps and S. Combettes, "A Cooperative SoS Architecting Approach Based on Adaptive Multi-Agent Systems," 2018 IEEE/ACM 6th International Workshop on Software Engineering for Systems-of-Systems (SESoS), Gothenburg, Sweden, 2018, pp. 8-16.
9. M. Li, M. Li, K. Yang, B. Xia and C. Wan, "A Network-Based Portfolio Optimization Approach for Military System of Systems Architecting," in *IEEE Access*, vol. 6, pp. 53452-53472, 2018, doi: 10.1109/ACCESS.2018.2870654.
10. B. Ge, K. W. Hipel, L. Fang, K. Yang and Y. Chen, "An Interactive Portfolio Decision Analysis Approach for System-of-Systems Architecting Using the Graph Model for Conflict Resolution," in *IEEE Transactions on Systems, Man, and Cybernetics: Systems*, vol. 44, no. 10, pp. 1328-1346, Oct. 2014, doi: 10.1109/TSMC.2014.2309321.
11. J. Hu, L. Huang, X. Chang and B. Cao, "A Model Driven Service Engineering approach to System of Systems," 2014 IEEE International Systems Conference Proceedings, Ottawa, ON, Canada, 2014, pp. 136-145, doi: 10.1109/SysCon.2014.6819248.
12. J. Hu, L. Huang, B. Cao and X. Chang, "Executable Modeling Approach to Service Oriented Architecture Using SoaML in Conjunction with Extended DEVSMML," 2014 IEEE International Conference on Services Computing, Anchorage, AK, USA, 2014, pp. 243-250, doi: 10.1109/SCC.2014.40.
13. Y. Mordecai, C. Chapman and D. Dori, "Conceptual Modeling Semantics for the Physical-Informational Essence Duality Problem," 2013 IEEE International Conference on Systems, Man, and Cybernetics, Manchester, UK, 2013, pp. 4505-4510, doi: 10.1109/SMC.2013.766.
14. Y. Mordecai, O. Orhof and D. Dori, "Model-Based Interoperability Engineering in Systems-of-Systems and Civil Aviation," in *IEEE Transactions on Systems, Man, and Cybernetics: Systems*, vol. 48, no. 4, pp. 637-648, April 2018, doi: 10.1109/TSMC.2016.2602543.
15. G. Muller, L. Elvebakk, J. van der Velde and F. M. Lean, "Roadmapping for Sustainability; How to Navigate a Social, Political, and Many Systems-of-Systems Playing Field? A Local Initiative," 2019 14th Annual Conference System of Systems Engineering (SoSE), Anchorage, AK, USA, 2019, pp. 317-322, doi: 10.1109/SYSOSE.2019.8753844.

## REFERENCES

- Acquisition Innovation Research Center (2022). [Report on Joint Capabilities Integration and Development System \(JCIDS\)](#).
- Acquisition Innovation Research Center (2023). [Agile Acquisition: History and Recommendations](#).
- US Army (2023). The P(i)lot to Kill JCIDS. [Army AL&T Magazine April 2023](#).
- Department of Defense (2019). Operation of the Middle Tier of Acquisition. DoD Instruction 5000.80. Washington, DC. December 30, 2019. [DoDI 5000.80 \(whs.mil\)](#).
- Department of Defense (2020). Operation of the Software Acquisition Pathway. [DoDI 5000.87](#).
- Department of Defense (2021). Charter of the Joint Requirements Oversight Council and Implementation of the Joint Capabilities Integration and Development System. Chairman of the Joint Chiefs of Staff Instruction [CJCSI 5123.011](#)
- Department of Defense (2021a). [Manual for the Operation of the Joint Capabilities Integration and Development System, 2021](#).
- Department of Defense (2022). Operation of the Adaptive Acquisition Framework. DoD Instruction 5000.02. January 23, 2020, Change 1, June 8, 2022. [DoDI Instruction 5000.02 \(whs.mil\)](#).
- Government Accountability Office (2021, October). Joint Staff Lacks Reliable Data on the Effectiveness of Its Revised Joint Approval Process.
- Modigliani, P., Ward, D., Lewis, T., & McGee, W. (2020) Modernizing DoD Requirements Enabling Speed, Agility, And Innovation. [MITRE Center for Technology and National Security](#).
- Schlomer, D. (2017). Strategies for Exploring: ACAT III Requirement Approval Process. Doctoral Dissertation. Retrieved from Walden University.
- Schlomer, D. & Campbell, D. (2018). Strategies to Streamline the U.S. Army's Acquisition Approval Process. International Journal of Applied Management and Technology, 17, 1, 58-67, doi:10.5990/IJAMT/2018.17.1.05
- United States Senate (2023). H.R.2670 as amended by the Senate on 27 July 2023. [Text - H.R.2670 - 118th Congress \(2023-2024\): National Defense Authorization Act for Fiscal Year 2024 | Congress.gov | Library of Congress](#).

## DISCLAIMER

Copyright © 2023 Stevens Institute of Technology. All rights reserved.

*The Acquisition Innovation Research Center (AIRC) is a multi-university partnership led and managed by the Stevens Institute of Technology and sponsored by the U.S. Department of Defense (DoD) through the Systems Engineering Research Center (SERC)—a DoD University-Affiliated Research Center (UARC).*

*This material is based upon work supported, in whole or in part, by the U.S. Department of Defense through the Office of the Under Secretary of Defense for Acquisition and Sustainment (OUSD(A&S)) and the Office of the Under Secretary of Defense for Research and Engineering (OUSD(R&E)) under Contract HQ0034-19-D-0003, TO#0480.*

*The views, findings, conclusions, and recommendations expressed in this material are solely those of the authors and do not necessarily reflect the views or positions of the United States Government (including the Department of Defense (DoD) and any government personnel) or the Stevens Institute of Technology.*

*No Warranty.*

*This Material is furnished on an “as-is” basis. The Stevens Institute of Technology makes no warranties of any kind—either expressed or implied—as to any matter, including (but not limited to) warranty of fitness for purpose or merchantability, exclusivity, or results obtained from use of the material.*

*The Stevens Institute of Technology does not make any warranty of any kind with respect to freedom from patent, trademark, or copyright infringement.*

